

iTherm® Piston Ring

PRODUCT DESCRIPTION

1 DESCRIPTION

Piston rings are used to assure sealing between the piston and the sleeve. Selection of piston rings is available to optimize production performance of different casting systems. Steel rings are offered for both iTherm® and Alrotec pistons

iTherm® Piston ring collection consists of longer front rings, which are made of steel and shorter back rings, usually made from steel or copper. Front rings are used in all types of iTherm pistons (V2.1, V3.1, V4.1), however, back rings are used only on iTherm Piston V3.1 and are especially designed for vacuum applications.



2 MAIN ADVANTAGES

- Sealing between the sleeve and the piston
- Good sliding properties
- Regularity on the casting process

iTherm® Piston Ring

TECHNICAL SPECIFICATIONS

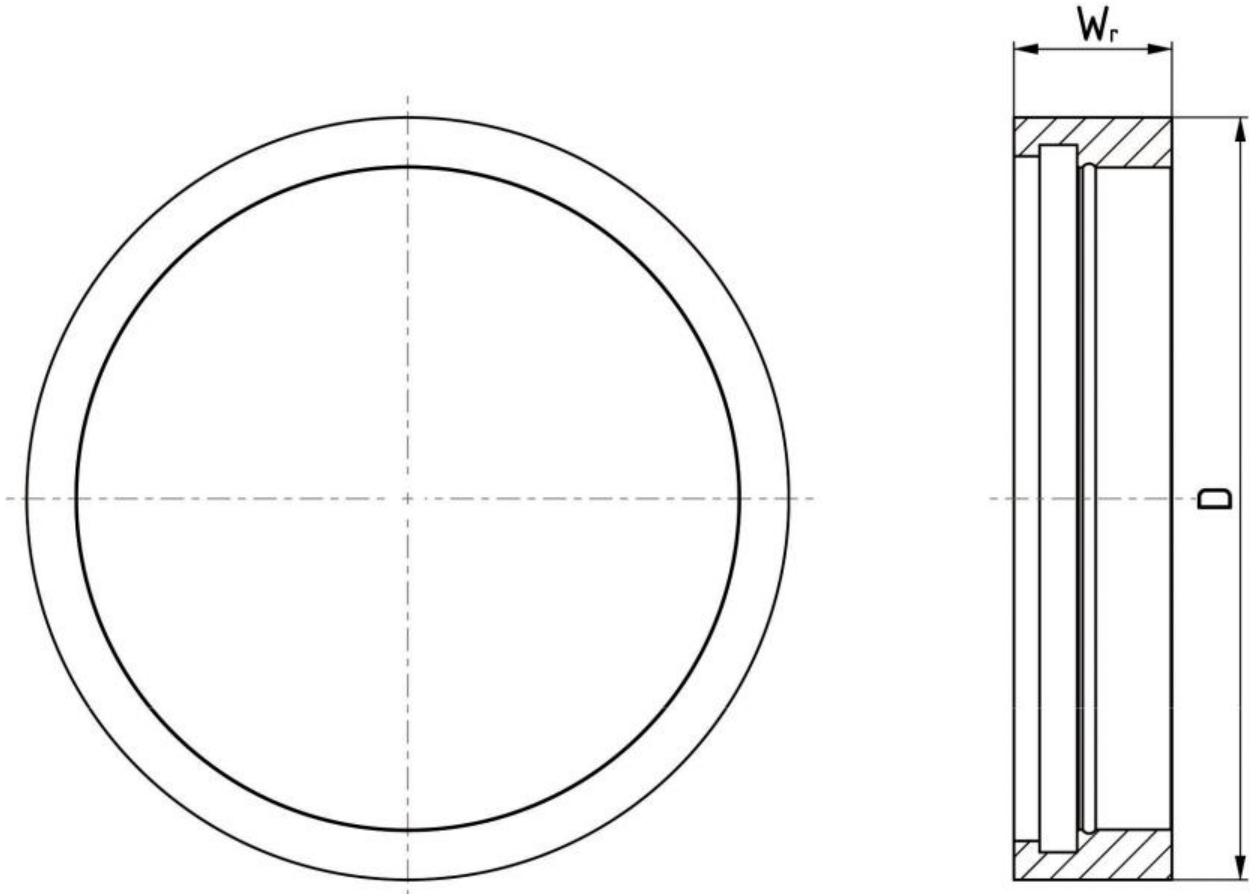

D	70	75	80	85	90	95	100	105	110	115
Wr-front ring	23	23,5	23,5	23,5	25	25	27	27	27	29,5
Wr-back ring	17	17,5	17,5	17,5	18	18	20	20	20	22

D	120	125	130	135	140	145	150	160	170	180
Wr-front ring	29,5	29,5	32	32	32	35	35	37,5	40	43
Wr-back ring	22	22	24	24	24	26	26	28	30	32

All dimensions are in mm

Do you need a slightly different
design or component?

We got you covered.

Contact our die casting professionals and we will do our best to match your requirements. You can count on us to support you through each step of performance improvement.

sales@hts-ic.com