

iTherm® Feed Ring

PRODUCT DESCRIPTION

1 DESCRIPTION

iTherm® is conformal-cooling single-body Feed ring with specially designed Internal Cooling System for reduction of cycle time and productivity improvement in HPDC.



2 MAIN ADVANTAGES

- Extra flexibility to bring cooling channels near the critical zones of feed ring
- Only has two connectors for cooling water (IN/OUT). With this, there is no possibility of leakage
- The heat is distributed much more even over the surface, so the ring is cooling down more evenly and quicker
- Time gain in phase of biscuit solidification, decreasing the biscuit problems related downtimes
- Significantly shorter cycle time. Our customers have reported up to 15% shorter cycle times

iTherm® Feed Ring

TECHNICAL SPECIFICATIONS

1 GENERAL DIMENSIONS

Ask for type in input, provide info on limits and tolerances.

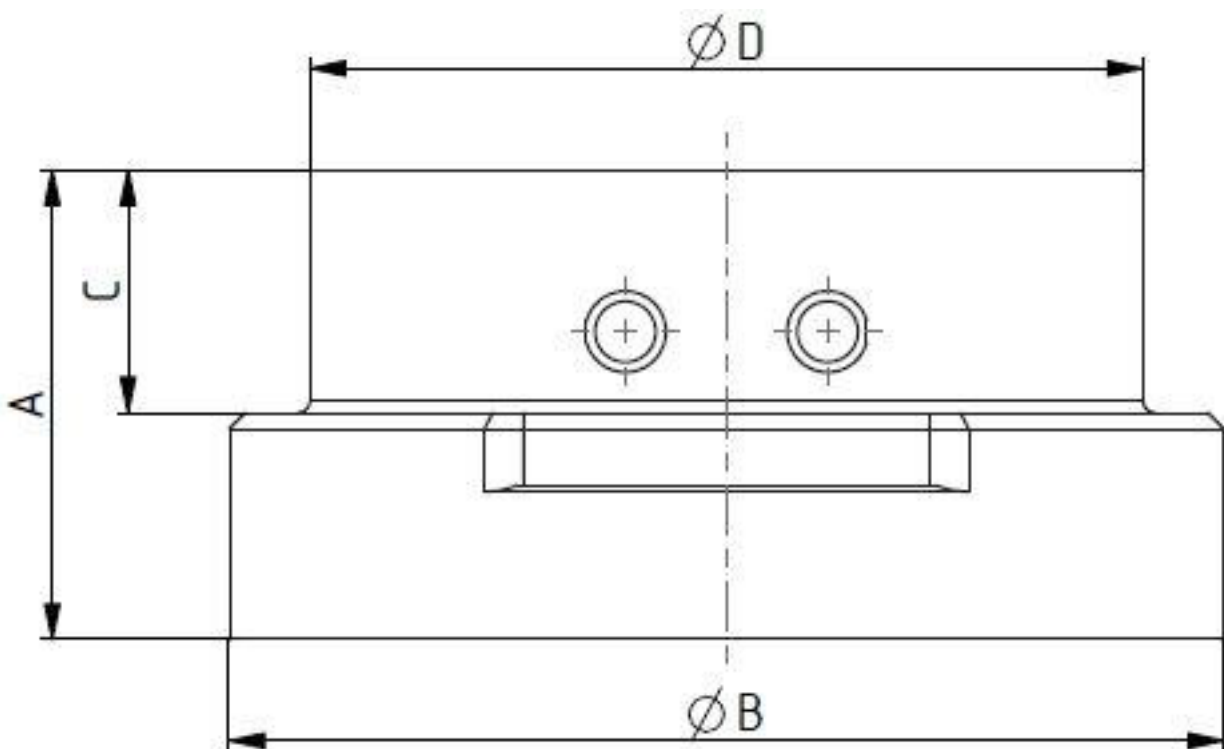

Parameter	Dimensions	Tolerances
A	75 - 155	$\pm 0,01$
$\varnothing B$	205 - 285	/
C	40 - 100	$\pm 0,01$
$\varnothing D$	165 - 245	$\pm 0,01$

All dimensions are in mm

iTherm® Feed Ring

TECHNICAL SPECIFICATIONS

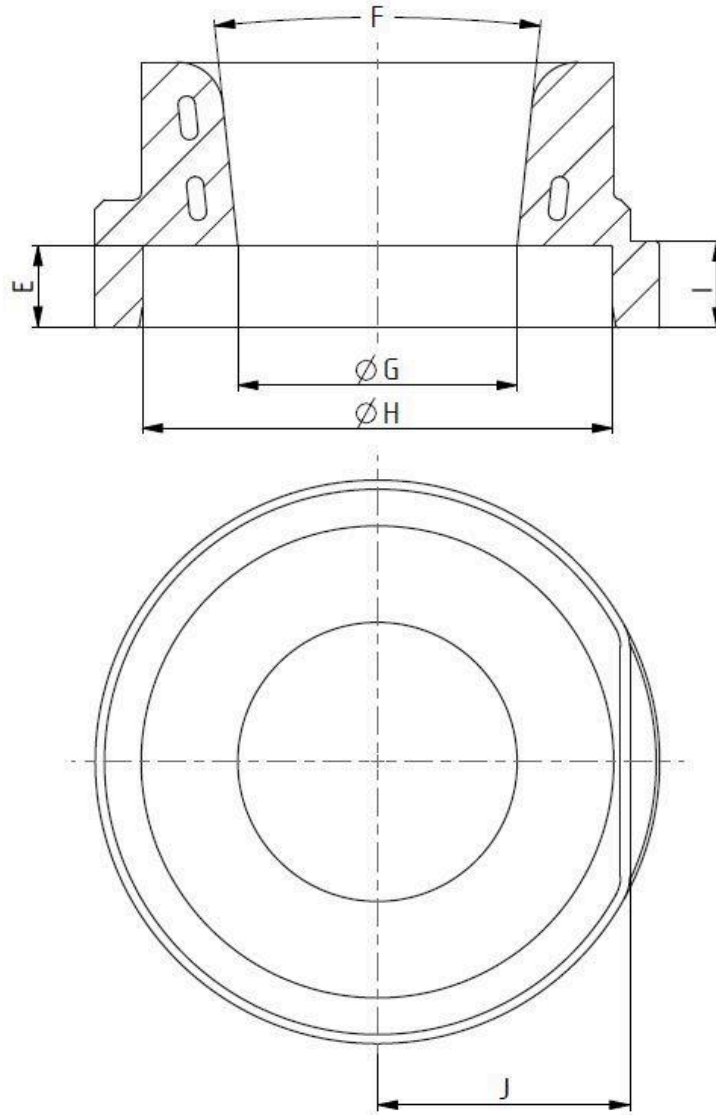

Parameter	Dimensions	Tolerances
E	20 - 75	± 0,01
F	12°	/
ØG	80 - 160	± 0,06/-0,02
ØH	165 - 245	± 0,03/-0,02
I	22 - 77	/
J	70 - 150	0/-0,03

All dimensions are in mm

iTherm® Feed Ring

TECHNICAL SPECIFICATIONS

2 COOLING POWER (W/cm²)

Provide selection, ask to select. No drawing needed.

- Low (10 W/cm²)
- Medium (20 W/cm²)
- High (30 W/cm²)

3 IN/OUT HOLES CONNECTION HOLES

Type Side for IN/OUT

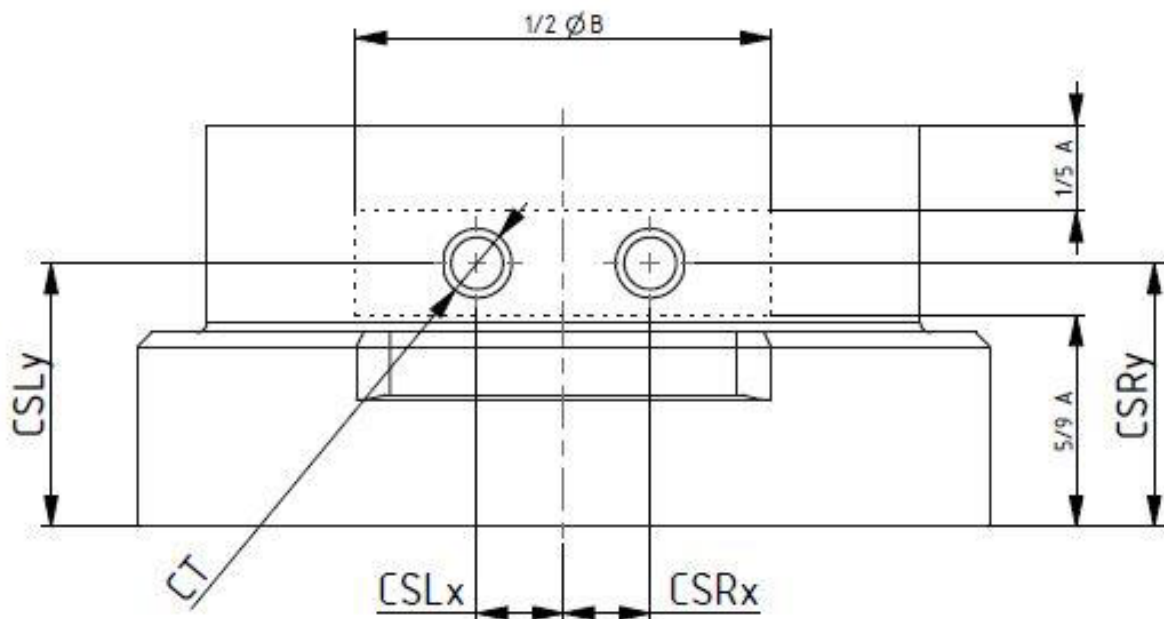

iTherm® Feed Ring

TECHNICAL SPECIFICATIONS

4 MATERIAL

- Dievar
- H11

5 MATERIAL PROPERTIES

44 - 48 HRC

Do you need a slightly different
design or component?

We got you covered.

Contact our die casting professionals and we will do our best to match your requirements. You can count on us to support you through each step of performance improvement.

sales@hts-ic.com